

SPECIFICATION FOR REFERENCE

CUSTOMER:	
CUSTOMER P.N.:	
MODEL NO.:	T30-T4170R480-200B0
PRODUCT NO.:	SDXXX-T0
LSSUE DATE:	2025-11-06

weight: 1500±100g

CUSTOMER AUTHORIZED SIGNATURE		

Please return to us one copy of "SPECIFICATION FOR APPROVAL"
with you approved signature.

**ADD: MOSO Industrial Park, Nanshan District, Shenzhen, Guangdong
518108, P. R. China**

TEL: 86-755-27657000

27657555

P.C.: 518108

FAX: 86-755-27657908

E-mail:moso@mosopower.com

<http://www.mosopower.com>

MANUFACTURER AUTOGRAPH			
Reviser	Confirm	Checked	Approval

**** Table of Content ****

1. SCOPE	5
1.1. Description.....	5
1.2. Green Requirements	5
2. Input Characteristics.....	5
2.1. Input Voltage & Frequency.....	5
2.2. Input AC Current.....	6
2.3. Inrush Current (cold start).....	6
2.4. Efficiency	6
3. Output Characteristics	6
3.1. Static Output Characteristics <Vo & R+N>.....	6
3.2. Line/ Load Regulation.....	6
3.3. Turn - on Delay Time.....	6
3.4. Output Overshoot / Undershoot.....	6
3.5. Output Load Transient Response	7
4. Protection Requirements	7
4.1. Over Current Protection.....	7
4.2. Short Circuit Protection	7
4.3. Over Voltage protection.....	7
4.4. Over Temperature protection	7
4.5. Degrees of Protection	7
5. Environment Requirements.....	7
5.1. Operating Temperature and Relative Humidity	7
5.2. Storage Temperature and Relative Humidity	8
5.3. Sea level shall be low 5,000 meters.....	8
5.4. Vibration.....	8
6. Reliability Requirements	8
6.1. Burn-in.....	8
6.2. MTBF.....	8
6.3. E-caps lifetime	8
7. EMC Standards/ EMC	8
7.1. EMI Standards/EMI	8
7.2. EMS Standards/EMS.....	8
8. Safety Standards	9
8.1. Dielectric Strength (Hi-pot).....	9
8.2. Leakage Current.....	9
8.3. Insulation Resistance	9
8.4. Grounding impedance test.....	9

8.5. Regulatory Standards.....	9
9. Mechanical Outline Drawing.....	10
10. I/O Marking Drawing.....	11
11. Package Drawing.....	12

1. SCOPE

The document detail the electrical, mechanical and environmental specifications of a SMPS, the power supply provide 200W continuous output power.

The power supply shall meet the HSF requirement.

1.1.Description

- | | |
|---|---|
| <input type="checkbox"/> SMPS Adaptor(Wall mount) | <input type="checkbox"/> SMPS Adaptor(Desk-top) |
| <input type="checkbox"/> Open Frame | <input checked="" type="checkbox"/> SMPS Unit (With Case) |
| <input type="checkbox"/> Others | |

1.2.Green Requirements

- RoHS:2011/65/EU & (EU) 2015/863;
- REACH:1907/2006/EC;
- Halogen-free:IEC 61249-2-21;
- CA Prop 65;
- POPs:(EU)2023/1608;
- PAHs: 2005/69/EC;
- Packaging Directive:94/62/EC;
- US EPA Toxic Substances Control Act (TSCA);
- MOSO Environmental standards: WI-QM006-G;
- Others

2. Input Characteristics

2.1.Input Voltage & Frequency

The range of input voltage is from 90Vac to 305Vac single phase.

	Minimum	Nominal	Maximum
Input Voltage	90Vac	100Vac~277Vac	305Vac
Input Frequency	47Hz	50Hz/60Hz	63Hz

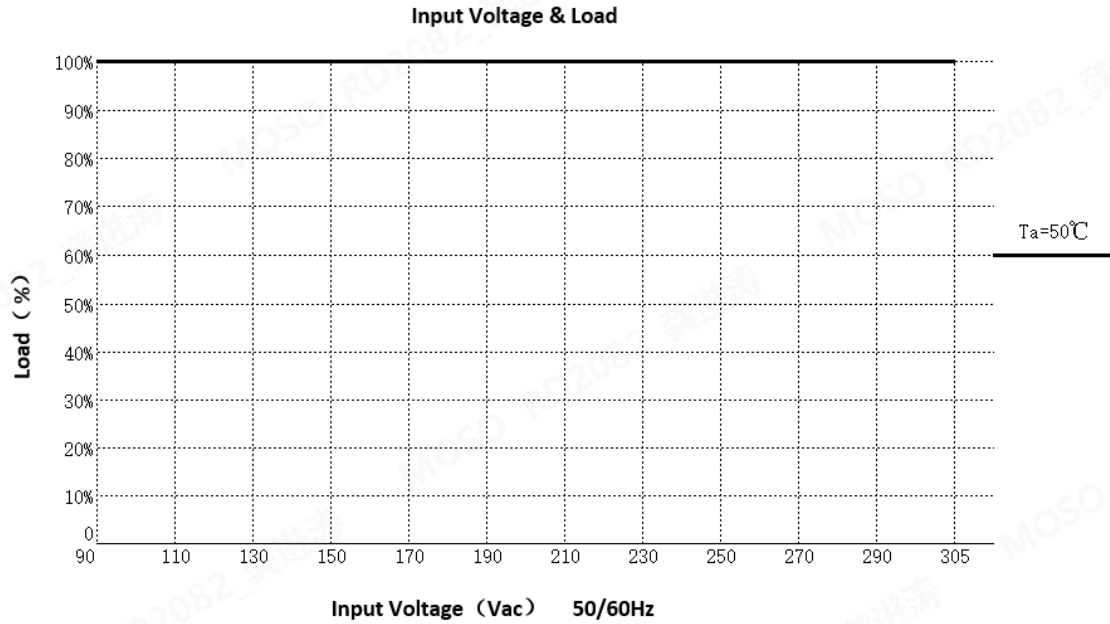

2.2. Input AC Current

2.8A max. @ 100-277Vac input & Full load.

2.3. Inrush Current (cold start)

150A max. @ 230Vac input

2.4. Efficiency

90% min. @ 115Vac/230Vac input @ Full load.

3. Output Characteristics

3.1. Static Output Characteristics <Vo & R+N>

Output Rate	Rated Load		Output Range	R+N	Remark
	Min. Load	Max. Load			
+48.0V	0.0A	4.17A	45.6~50.4V	<960mVp-p	90-305V

Ripple & Noise: Measurement is done by 20MHz bandwidth oscilloscope and the output paralleled a 0.1uF ceramic capacitor and a 47uF Electrolytic capacitor. (Test under the condition of rated input and rated output).

3.2. Line/ Load Regulation

Output Rate	Load Condition		Line Regulation	Load Regulation	Remark
	Min. Load	Max. Load			
+48.0V	0.0A	4.17A	± 3%	± 5%	115V-230V

3.3. Turn - on Delay Time

3S max. @ 115-230Vac input & Full load.

3.4. Output Overshoot / Undershoot

10% max. When the power on or off, when it is the full input voltage and full load.

3.5. Output Load Transient Response

Output voltage within 43.2~52.8V for load step from 25% to 50%, 50%~75%, 75%100%
R/S: 0.5A/uS,
Frequency: 100Hz duration and 2mS at 100%.

4. Protection Requirements

4.1. Over Current Protection

Over Current Point Limited: $8.34A > I > 4.6A$ (100-277Vac)

The output shall hiccup when the over current applied to the output rail, and shall be self-recovery when the fault condition is removed.

4.2.Short Circuit Protection

The input power shall decrease when the output rail short, the power supply shall no damage, and shall be self-recovery when the fault condition is removed.

4.3.Over Voltage protection

When the output voltage is over 1.1-1.5 Rated Load Voltage, the driver shuts off automatically and enters protection status, the driver will work normally after fault condition removed and AC input reapply.

4.4.Over Temperature protection

When the Tc temperature exceeds $105^{\circ}\text{C} \pm 5^{\circ}\text{C}$, the PSU automatically reduces the output power and enters the protection state. When the Tc temperature is lower than $105^{\circ}\text{C} \pm 5^{\circ}\text{C}$, the power supply automatically recovers.

4.5.Degrees of Protection

IP67

5. Environment Requirements

5.1.Operating Temperature and Relative Humidity

-40°C to +60°C

5%RH to 95%RH

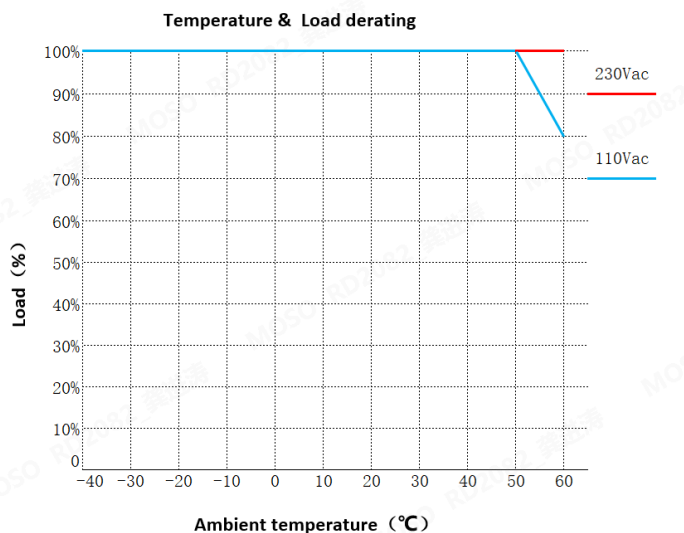

5.2.Storage Temperature and Relative Humidity

-40°C to +85°C
5%RH to 95%RH non-condensing

5.3. Sea level shall be low 5,000 meters.

5.4.Vibration

10 to 300Hz sweep at a constant acceleration of 1.0G (Breadth: 3.5mm) for 1Hour for each of the perpendicular axes X, Y, Z.

6. Reliability Requirements

6.1. Burn-in

The power supply shall be burn-in for 4 Hours under normal input and 80% rated load at 50°C ± 5°C @ 100Vac/240Vac.

6.2.MTBF

The MTBF of power supply shall be over than 200,000Hours @ 25°C, 80% load & 115Vac/230Vac input .

6.3.E-caps lifetime

The E-caps used in this PSU must be with lifetime of 26,280H at 50°C@115Vac/230Vac with full load.

7. EMC Standards/ EMC

7.1. EMI Standards/EMI

FCC Part15 EN55032 EN55035 AS/NZS CISPR32 CNS 15936
GB/T9254 GB17625.1

7.2.EMS Standards/EMS

7-2-1 EN 61000-4-2, electrostatic discharge (ESD) requirement

Discharge characteristic	Test level	Test criteria
Air discharge	+/-8KV	B
Contact discharge	+/-4KV	B

7-2-2 EN 61000-4-3, radiated electromagnetic field susceptibility (rs)

Test level	Test criteria
3V/m (r.m.s)	A
80-1000MHz,80%AM(1KHz) sine-wave	

7-2-3 EN 61000-4-4, electric fast transients (burst) immunity requirement

Coupling	Test level	Test criteria
AC-input	1KV	A
AC-input	1KV	A

7-2-4 EN 61000-4-5, surge capability requirement

Surge voltage	Test criteria
Common mode +/-10KV	A
Differential mode +/-5KV	

7-2-5 EN 61000-4-6, Induced radio frequency fields conducted disturbances immunity requirement

Test level	Test criteria
3V	A
0.15-80 MHz,80%AM(1KHz)	

7-2-6 Assessment criteria

Acceptance criteria	Performance
A	Agreed operational behavior within the specified limits
B	Time limited functional diminishment or malfunction during the tests is permitted. The function is self-reactivated by the unit following completion of the tests.
C	Malfunction is permitted .The function can be reactivated either by reconnection to the mains or by operator intervention.

8. Safety Standards

8.1. Dielectric Strength (Hi-pot)

I/P-O/P: 3KVac/10mA max. / 60 seconds.

I/P-FG: 1.5KVac/10mA max. / 60 seconds.

8.2.Leakage Current

0.5mA max. at 264Vac / 60Hz.

8.3.Insulation Resistance

100MΩ min. at primary to secondary add 500Vdc test voltage.

8.4.Grounding impedance test

Grounding Resistance: <0.10 Ω at 25A/60S.

8.5.Regulatory Standards

Type	Country	Standard	State	Note
CE	Europe	EN62368-1	APPROVAL	
UKCA	UK	EN62368-1	APPROVAL	
UL	USA	UL62368-1	APPROVAL	
BSMI	China taiwan	CNS15598-1	APPROVAL	
NOM	Mexico	NOM-001-SCFI-2018	APPROVAL	
RCM	Australia	AS/NZS62368.1	APPROVAL	
CQC	China	GB4943.1	APPROVAL	

9. Mechanical Outline Drawing

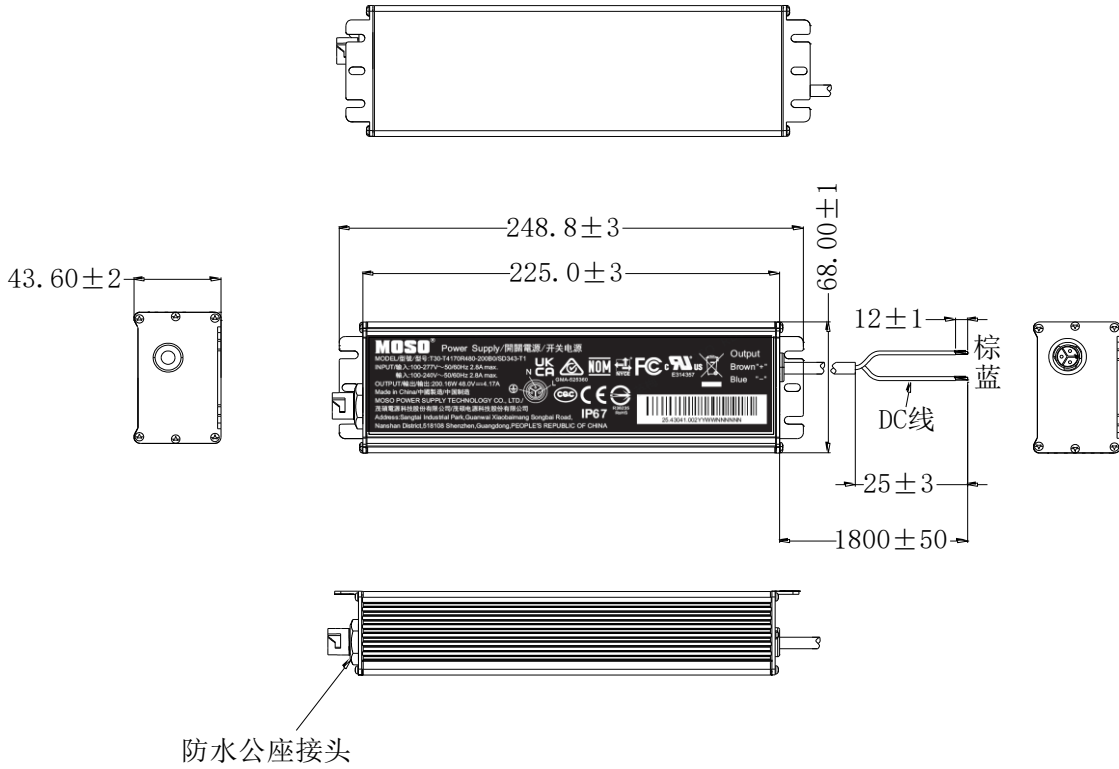

10. I/O Marking Drawing



备注:

- 1、100# PET+光膜,压花格底纹胶(加强胶),黑底白字;
- 2、垃圾桶标识尺寸高度不小于7mm;
- 3、符合RoHS,REACH及茂碩环保要求;
- 4、背胶耐温90°C,96h内不翘角,不脱落,不起泡;
- 5、酒精擦拭和清水各擦15秒,用100克的砝码包棉布擦,字体清晰可见,无其他不良(如卷边、翘角等)

客户料号, 固定不变
Year(年): 2015年表示为15, 2016年表示为16
Week(周别): 第一周标示为01
流水码: 000001-999999, 按周清零, 每周需从000001起编

11. Package Drawing

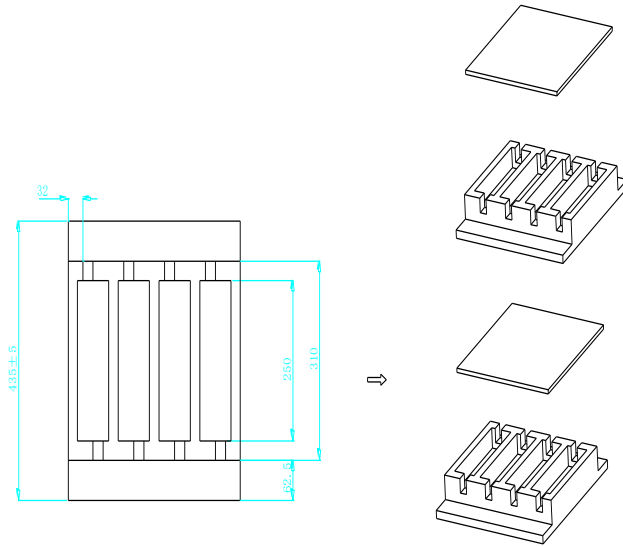

Packing Instruction:

- 1、The packing product put in the partitioning card groove, 4PCS/floor, 2 floors in all, 8PCS/box
such as: 4pcs/floor*2floor=8PCS/box
- 2、the usage of the packing materials:
 - 1) the usage of the EPE foam 435*375*80: 2PCS
 - 2) the usage of the EPE flat 435*375*10: 2PCS
 - 3) carton box 450*390*200: 1PCS
- 3、Pallet stack instruction:
 - 1) Pallet size is:L1200*W950*H135mm
 - 2) per floor set 6pcs
 - 3) stacke per 5floor*6pcs carton total 30 pcs carton

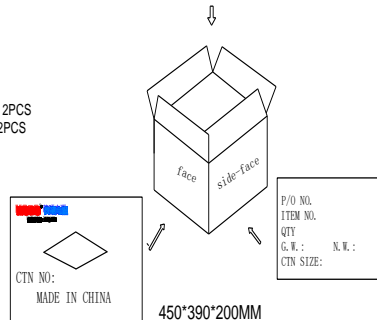

The outer dimensions of the cardboard box: 450L*390W*200H

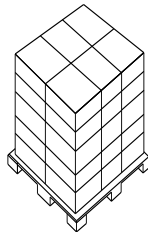

The pallet stack drawing

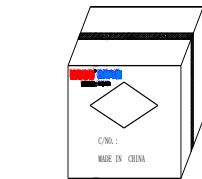

The product is packed into a packaging box and sealed with a plastic bag, as shown in the diagram

- The requirement of PE bag packing: PE bag without sealing by adhesive tape.
 PE bag with sealing by adhesive tape
 Other requirement

Remark: If the customer has not chose the PE bag packing way,
We will use the PE bag without sealing by adhesive tape.